

Hanwha Power

Headquarters	Korea	6, Pangyo-ro 319beon-gil, Bundang-gu, Seongnam-si, Gyeonggi-do	Tel +82.70.7147.8000
	USA	1440 W. Indiantown Rd. Jupiter, FL 33458	Tel +1 561.354.1100
Factory	Changwon 1	1204, Changwon-daero, Seongsan-gu, Changwon-si, Gyeongsangnam-do, Korea	
	Changwon 2	69, Gongdan-ro, Seongsan-gu, Changwon-si, Gyeongsangnam-do, Korea	
	Busan 3	31, Gwahaksandan 2-ro, Gangseo-gu, Busan, Korea	

Global Network

• Asia-Pacific

Shanghai, China
200233 20/F, New Caohejing International Business Center A,
No391, Guiping Road, Shanghai, China
Tel +86.21.5427.1155 (8510)

Tianjin Office
300385 2/F, Building 2, No.16, Weier Road, microelectronics
industrial zone, Xiqing district, Tianjin City, China

Vietnam Office
6F, Star Tower, Cau Giay new urban area, Duong Dinh Nghe Street,
Yen Hoa Ward, Cau Giay District, Hanoi, Vietnam
Tel +84.24.3201.2450

• Americas

Houston, USA
580 Westlake Park Blvd, Suite 500, Houston TX 77079, USA
Tel +1.281.599.3377 ext.204

• Middle East

Abu Dhabi, UAE
PO BOX 33586, Plot #35-WR43, ICAD 3 Musaffah South, Abu Dhabi, UAE
Tel +971.2.627.0151

Khobar, KSA
Unit 4, 12TH Floor, Al fardan Tower, Khobar 31952, KSA
Tel +966.1.3812.3155

• Europe

Milan, Italy
Via de Vizzi 93/95, Cinisello Balsamo 20092, Milan, Italy
Tel +39.02.8410.2193

• CIS

Moscow Office
5F, Bolshaya Serpukhovskaya Str., 7, Moscow, Russia 115191
Tel +7.495.11.5260

Website : www.hanwhapower.com
E-mail : hanwhapower@hanwha.com



Turbo Compressor Certification Status

- ISO 9001
- ISO 14001
- ISO 45001
- CE(DOC)
- PED
- UL

The information contained in this document is subject to change without prior notice.

OIL-FREE CENTRIFUGAL AIR COMPRESSOR

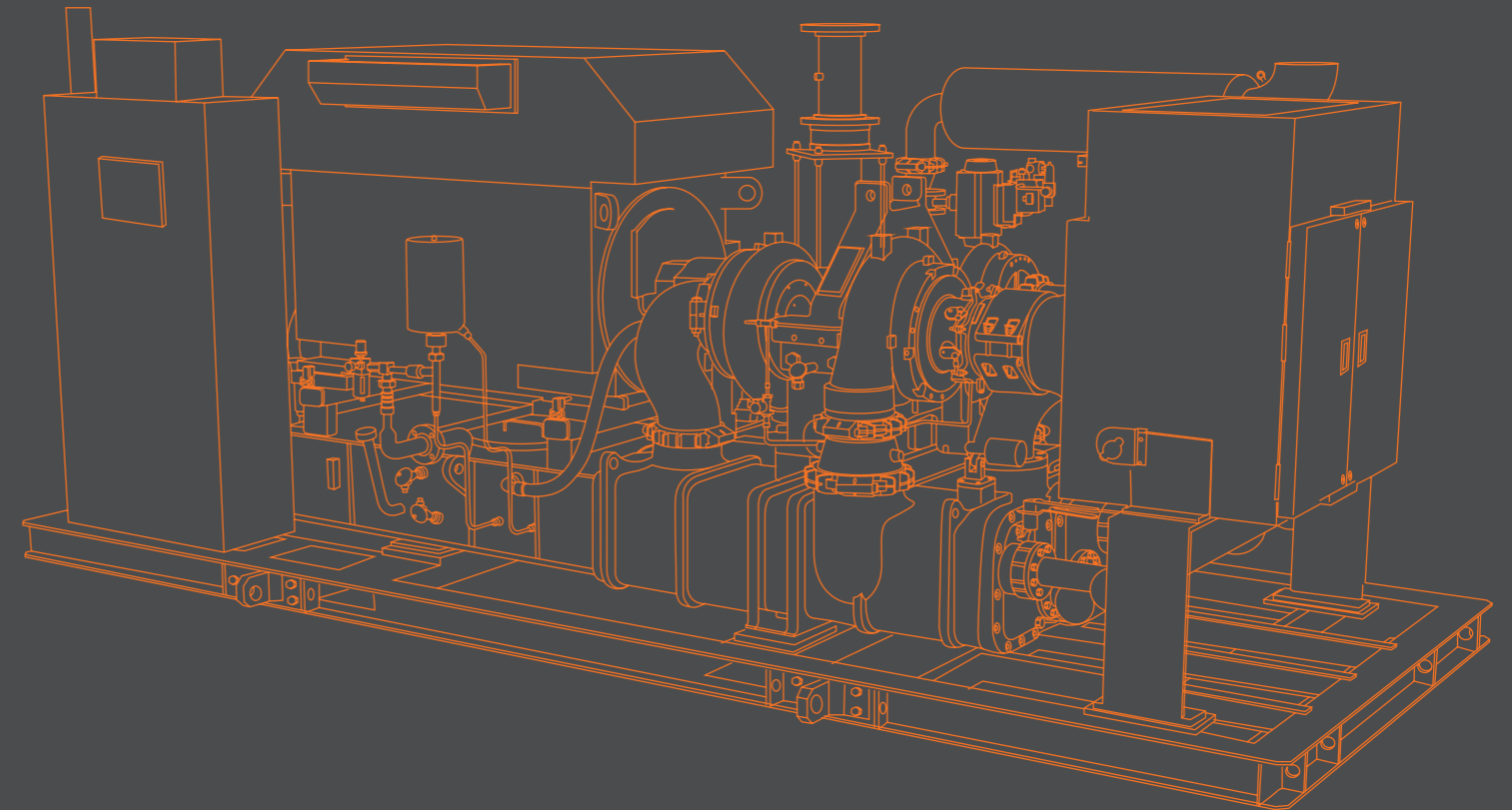

Worldwide Network



 Global Entities & Offices

 Service Center

Introduction to Hanwha Power

With a solid foundation of long-term reliability and experience in the gas turbine engine field, Hanwha Power entered the industrial energy equipment market in 1997.

Since then, it has grown into a global company, with a sales record of over 9,000 units worldwide. The company's product range, which includes air compressors for various industries, oil & gas,

air separation, and fuel gas compressors for power plants, BOG (Boil Off Gas) compressors for LNG terminals, cryogenic compressors, companders, and shipbuilding and marine compressors, is a reflection of its enduring commitment to high added value.

History

- **1977** Company Establishment
- **1979** Aircraft Gas Turbine Engine Overhaul Business Launch
- **1996** Industrial Gas Turbine Development
- **1997** Industrial Air Compressor Business Start
- **2011** Gas Compressor Market Entry
- **2013** Launch of the world's largest air-cooled turbo compressor (SA3100)
- **2014** Marine Compressor Market Entry
Signing of the world's first supply contract for offshore VRU (vapor recovery) turbo compressor
- **2016** Approved vendor registration with Saudi Aramco (API 617 process compressors & blowers)
- **2018** Launch of eco-friendly, high-efficiency energy solution pressure reducing generator (TEG)
- **2020** Supply contract signed for hydrogen charging system at KOGAS complex energy supply hub
- **2021** Received and achieved DOE (Department of Energy) national project for sCO₂ power system
- **2022** sCO₂ power system wins global R&D100 Award
Entry into ethylene compressor and CO₂ compressor markets
- **2023** Successfully demonstrated world's first full combustion of hydrogen turbine
- **2024** 174K LNGC vessel Nitrogen Re-liquefaction System technology approved (ADNOC)
- **2025** Joint Development and Cooperation Agreement with Baker Hughes for ammonia gas turbine
New air compressor product launch (SM100 Pro)
- **2026** Company name changed to Hanwha Power

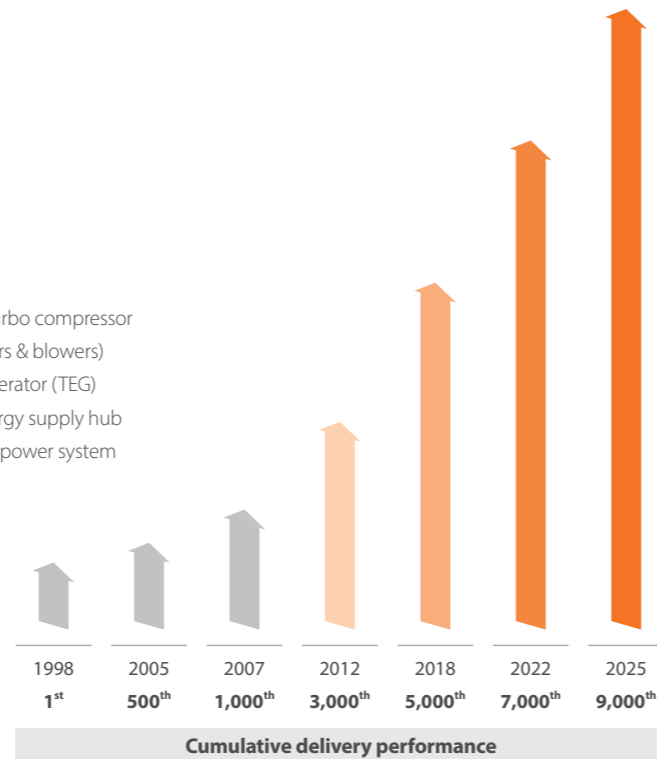

Applicable Industries



Oil & Gas

- Instrument Air
- API 617 & API 672



Petrochemical

- Ethylene
- Polymers
- EO/EG
- Fine Chemicals
- Fertilizers
- PTA
- PDH



Power Plant

- CCPP (Combined Cycle Power Plant)
- Instrument Air



General Industry

- Electronic
- Industrial Manufacturing Facilities (Automobile, Shipbuilding)
- Mining, Construction & Others
- Food, Glass, Paper, etc.



Air Separation

- Gas Processing & Treatment
- LNG Terminal & Liquefaction
- Cryogenic Solutions



Steel/Metal

- Steel Mills
- Non-Ferrous Plants (Al, Copper, Nickel, etc)
- Air Separation

Total Solution

Compressor Room Total Solution

We check the operating status of the customer's entire compressor room air system to recommend the most efficient equipment operation plan. We also measure and analyze actual operating data, such as flow rate and power consumption, to suggest an economical compressor operation plan that reduces energy usage. Diagnosis takes up to 2 weeks.

Process

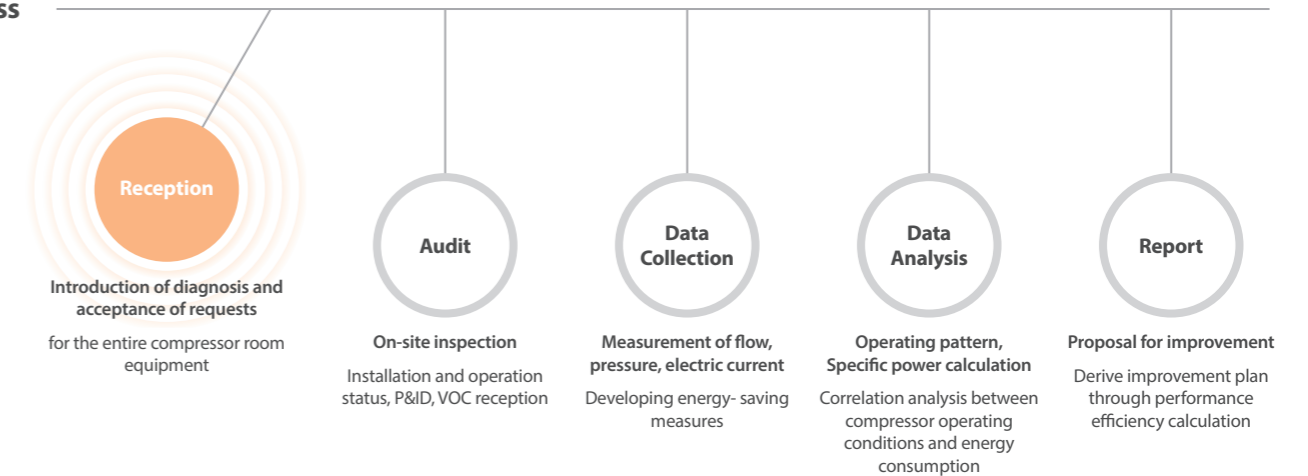

Monitoring

Extend compressor life, maximize availability, and minimize downtime through remote monitoring.

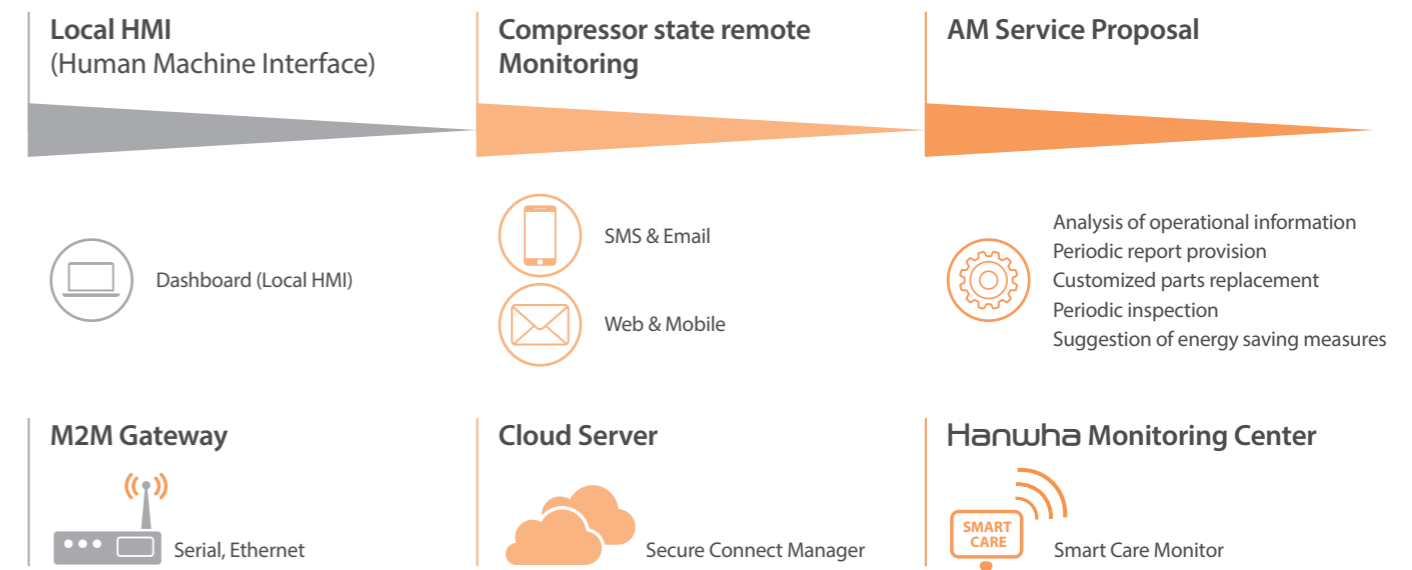

Dependable Products Lineup



100% Oil-Free

Integrally Geared Type

Hanwha Power turbo compressor (Integrally Geared Type) promises excellent performance and efficiency through proprietary technology.

We supply clean, dry '100% Oil-Free' air to maintain optimal production conditions while complying with strict environmental regulations. This is why we are recognized for safety and reliability as the best-customized solution in various industries.

ISO8573-1 Class 0 Clean Air Supply

Our products have achieved the prestigious ISO8573-1 Class 0 certification, representing the highest quality standard for compressed air. They are extensively utilized across industries that demand high reliability, including advanced sectors such as semiconductors and batteries, as well as steel, chemical, and food industries.

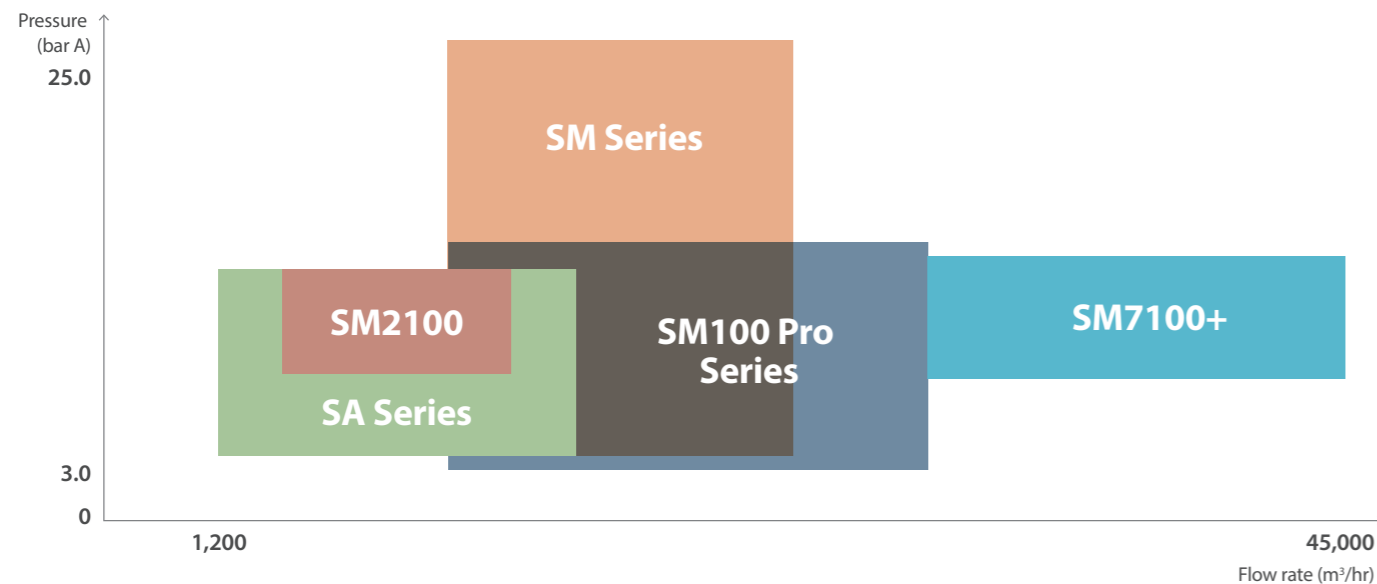
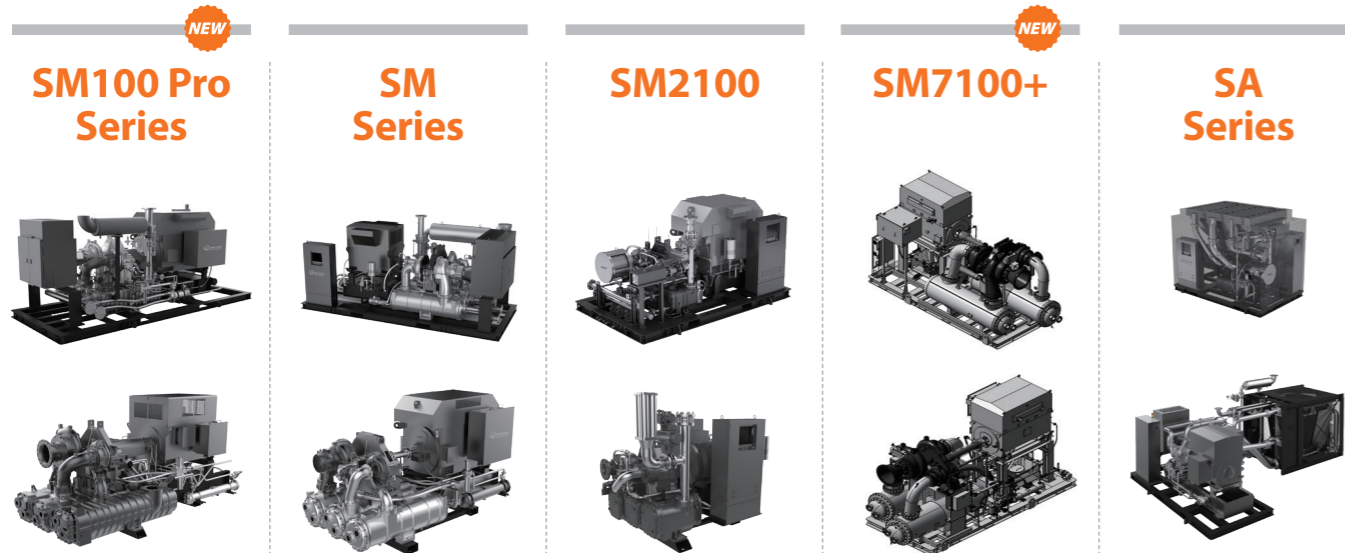

Key Technical Feature

Concentrating on Efficiency with Reliability

Optimized components and simple design ensure high efficiency and stable operation.

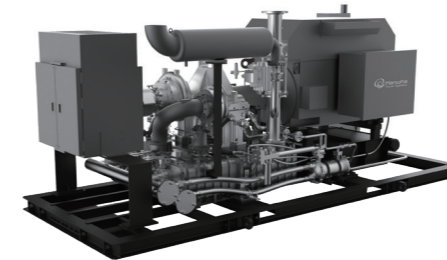

Customized high-performance, high-reliability of turbo compressors

- Achieving high efficiency and energy saving through proprietary designs and technologies
- Compliant with various international standards including API, ASME, PED, and KOSHA
- Providing 100% Oil Free solution (ISO8573-1 Class 0)
- Simple structure offering easy installation/maintenance
- Customized solutions including complete compressed air systems per specific user requirements

High-durability gear system based on sophisticated technology

- Delivering peak performance based on over 30 years of accumulated design expertise
- High reliability and durability verified through numerous operating experiences
- Reduced maintenance time through easy disassembly on site

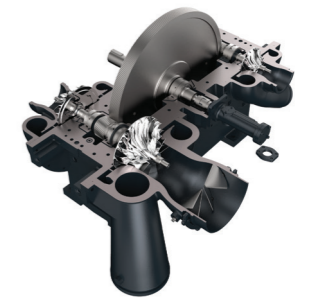

Impeller manufactured based on proprietary/advanced design technology

- Maximize optimal stability and energy efficiency through sophisticated design
- High reliability through low vibration and low noise achievement
- Implementation of optimized customer-specific designs

High-durability Coolers

- Optimal airflow design to minimize pressure drop
- Excellent durability achieved by applying materials suitable for the user environment
- Easy to clean and maintain with a water-in-tube type

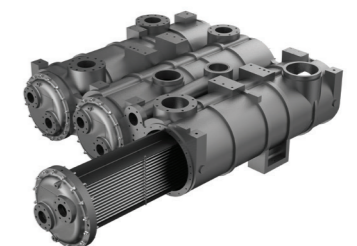

Provide the best interface for users

- Provide user-oriented convenience (high-resolution color application)
- Apply a wide touch-screen for customer convenience
- Implement a compressor diagnosis and alarm provision system through real-time monitoring

High Efficiency & High Profit

SM100 Pro Series NEW

Features

- ✓ Provide environmentally friendly solutions that contribute to reducing CO₂ emissions
- ✓ through improved energy efficiency
- ✓ Improve efficiency and expanding flow range by optimizing aerodynamic components
- ✓ Up to 5% efficiency improvement compared to our existing products
- ✓ Provide various options and solutions according to customer operating conditions and environments
 - Provide secondary battery-oriented Cu-Zn Free solutions
 - Possible to operate in outdoor environments
 - Manufacture Combo compressors
 - Possible to design according to customer-required discharge temperature conditions
 - Possible to manufacture products certified required by each country (KGS/PED/TRCU/UKRSEPRO/CRN/CSA)

Specifications

Model		SM3100 Pro	SM4100 Pro	SM5100 Pro	SM6100 Pro	SM7100 Pro	
Capacity	m ³ /hr	3,300 ~ 5,690	4,340 ~ 9,030	7,350 ~ 15,150	11,630 ~ 25,890	24,500 ~ 36,000	
	CFM	1,950 ~ 3,240	2,480 ~ 5,160	4,200 ~ 8,670	9,800 ~ 14,800	14,400 ~ 21,150	
Power	kW	250 ~ 600	460 ~ 900	570 ~ 1,500	870 ~ 2,520	1,000 ~ 2,800	
	HP	270 ~ 800	620 ~ 1,220	770 ~ 2,015	1,170 ~ 3,380	1,340 ~ 3,753	
Discharge Pressure	bar A	3.0 ~ 13				3.5 ~ 11.4	
	Psi A	43 ~ 188				50 ~ 165	
Dimension (L x W x H)	mm	P	5,250 x 2,250 x 2,500	5,500 x 2,250 x 2,500	6,250 x 2,250 x 2,550	7,100 x 2,250 x 2,550	-
		S	3,210 x 2,150 x 1,920	3,800 x 2,300 x 2,050	4,750 x 2,490 x 2,130	5,290 x 2,400 x 2,420	5,700 x 2,800 x 2,950

* P : Package type / S : Standard type

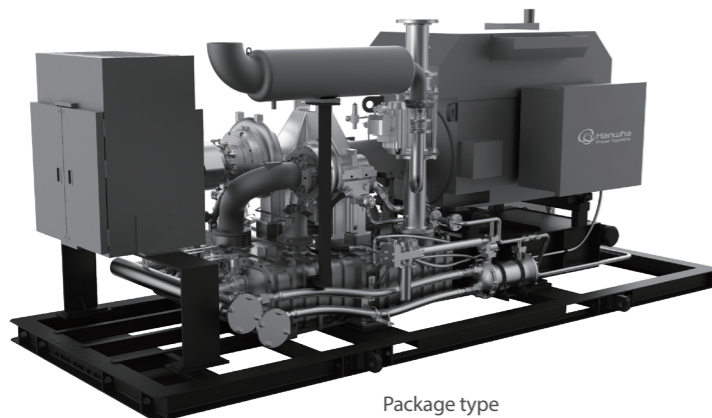

Package type

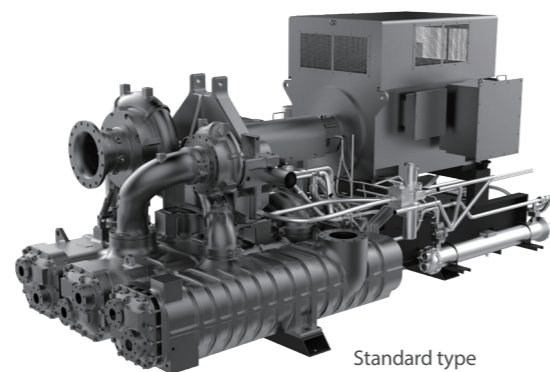

Standard type

Driving Performance

SM Series

Features

- ✓ Standard for industrial air compressors based on high stability and operational reliability
- ✓ High-quality air compression system based on API672 Code design
- ✓ Customized equipment is available
 - High-pressure compressors of 14 bar A or higher can be manufactured
 - Nitrogen compressors can be manufactured (Carbon Seal Type applied)
 - Combo compressors can be manufactured
 - Booster compressors can be manufactured
 - Country-specific certified products can be manufactured (KGS/PED/TRCU/UKRSEPRO/CRN/CSA)
- ✓ High compatibility / Fast service response
 - Respond with the shortest lead time through compatibility of consumable parts for all models (minimizing troubleshooting period)

Specifications

Model		SM3000	SM4000	SM5000	SM6000	
Capacity	m ³ /hr	3,300 ~ 5,300	5,300 ~ 8,400	8,400 ~ 15,000	15,000 ~ 21,000	
	CFM	1,950 ~ 3,100	3,100 ~ 4,950	4,950 ~ 8,850	8,850 ~ 12,400	
Power	kW	230 ~ 710	360 ~ 1,200	560 ~ 1,800	940 ~ 2,650	
	HP	300 ~ 950	480 ~ 1,600	750 ~ 2,410	1,260 ~ 3,550	
Discharge Pressure	bar A	3.5 ~ 25				
	Psi A	50 ~ 364				
Dimension (L x W x H)	mm	P	4,750 x 2,100 x 2,500	5,100 x 2,250 x 2,500	5,450 x 2,250 x 2,500	6,200 x 2,300 x 2,550
		S	3,150 x 1,980 x 2,100	3,780 x 2,080 x 2,130	3,960 x 2,100 x 2,350	4,480 x 2,220 x 2,520

* P : Package type / S : Standard type

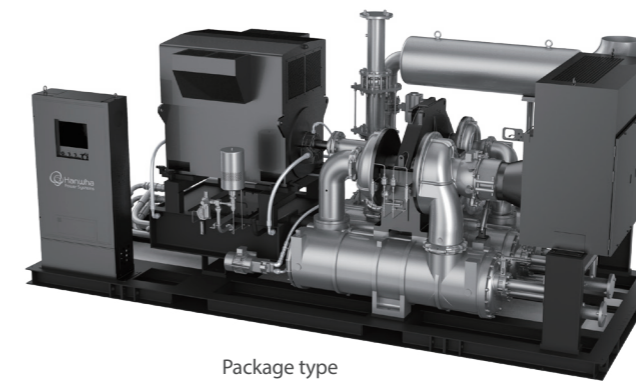

Package type

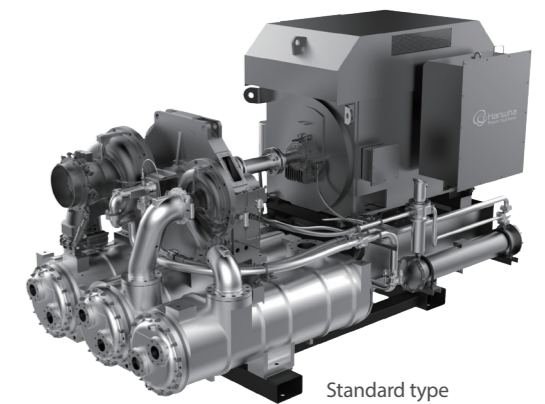

Standard type

Driving Performance & Low Flow

SM2100

Features

- ✓ Customized options tailored to specific customer requirements
- ✓ Solutions available from basic expandable models to plug-and-play package configurations, with selectable options
 - Optional components: Base Frame, Cooling Water Manifold, Enclosure - inclusion or exclusion per requirements
- ✓ Tilting pad journal bearing applied to Easy Pinion Gear for stable operation and extended service life
(Bearings replacement recommended based on operating conditions)
- ✓ Compact design for minimal installation footprint
- ✓ Vibration sensor, oil heater, oil tank vacuum gauge included as standard
- ✓ Four-stage API-compliant sealing system for minimized gas leakage
- ✓ High-efficiency inlet guide vanes for reduced power consumption via partial load control
- ✓ Five-axis machined impeller for optimal stability and efficiency

Specifications

Model		SM2100	
Capacity	m ³ /hr	1,400 ~ 3,550	
	CFM	824 ~ 2,089	
Power	kW	150 ~ 335	
	HP	200 ~ 450	
Discharge Pressure	bar A	5.0 ~ 11.4	
	Psi A	72 ~ 165	
Dimension (L x W x H)	mm	P	3,400 x 2,200 x 2,066
		S	2,360 x 1,660 x 1,770

* P : Package type / S : Standard type

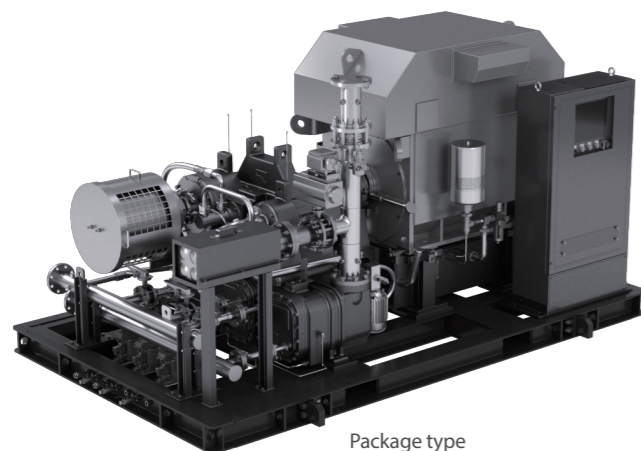

Package type

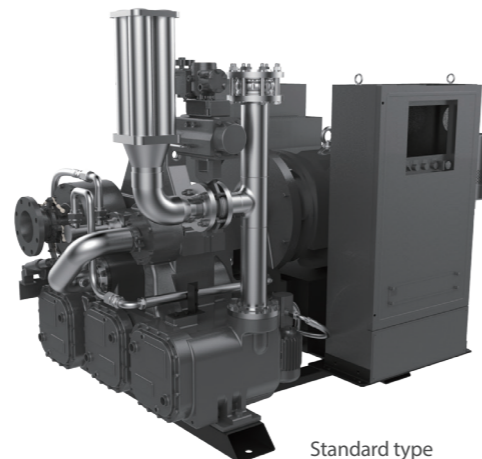

Standard type

High-tech Intensive

SM7100+ NEW

Features

- ✓ Standard design basis for high-flow compressors enables optimized product recommendations
- ✓ Advanced engineered compressor design by Hanwha Power ensures superior durability, validated by extensive proven references
- ✓ Master impeller precision-manufactured with 4th-generation CNC 5-axis machining minimizes energy loss via optimized aerodynamic design
- ✓ Compact equipment footprint enhances on-site accessibility and inspection efficiency

Specifications

Model		SM7100 +	
Capacity	m ³ /hr	32,000 ~ 45,000	
	CFM	18,835 ~ 26,487	
Power	kW	2,300 ~ 4,000	
	HP	3,038 ~ 5,361	
Discharge Pressure	bar A	5.0 ~ 11.5	
	Psi A	72 ~ 166	
Dimension (L x W x H)	mm	S	6,201 x 3,234 x 3,816

* S : Standard type

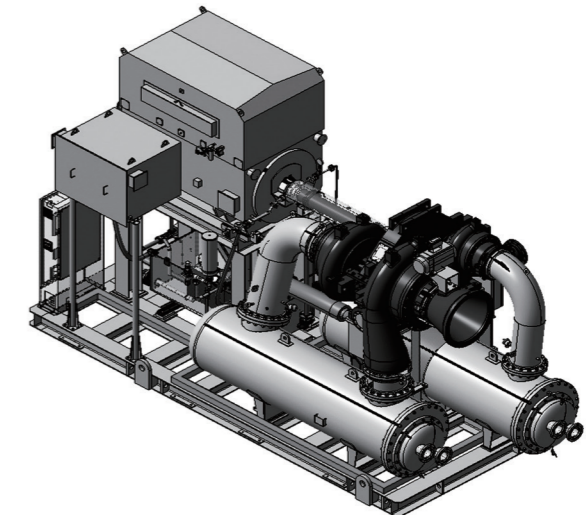

Designed with Modern Engineering

SA Series

Features

- ✓ High-precision AGMA 12 & 13 gear system ensures noise reduction and extended service life
- ✓ Easy maintenance with individually replaceable pinion and bull gears
- ✓ Master impeller made of 17-4 PH stainless steel
- ✓ High-efficiency impeller, 5-axis machined, with a wide turndown range (meets API 672 standard)
- ✓ High-quality split-type tilting pad journal bearing for stable operation of the pinion gear
- ✓ Sleeve journal and taper-landed bearing design to minimize friction loss
- ✓ Bearings compatible with RTD (SA3100 option available)
- ✓ Sealing system compliant with API standards
- ✓ No separate compressed air required for sealing, effectively preventing air and oil leakage
- ✓ Split-type design allows inspection and maintenance without rotor disassembly

Specifications

Model		SA2100	SA3100
Capacity	m ³ /hr	1,200-2,890	3,750-5,500
	CFM	700-1,680	2,200-3,250
Power	kW	150-260	400-580
	HP	200-350	540-780
Discharge Pressure	bar A	3.5-11.4	3.5-11
	Psi A	50-165	50-160
Dimension (L x W x H)	mm		
	Compressor	3,000x2,500x1,900	4,650 x 2,050 x 1,990
	Cooler	-	4,420 x 2,110 x 2,290

* Flexible cooler options are available (SA3100).

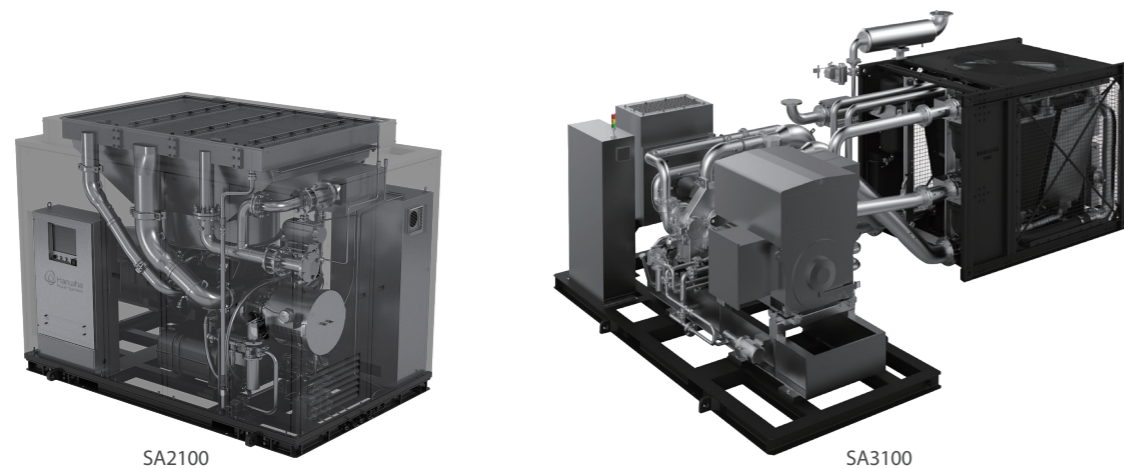

Services

Smart Care Service

We provide fast and innovative care services using Hanwha's high-quality genuine parts and advanced technology, enabling you to focus on stable maintenance and equipment operation.

Minimize Equipment Downtime

RUSH 112 Worldwide

Hanwha Power is committed to minimizing equipment downtime through our RUSH 112 policy, which ensures rapid and reliable service for our customers.

Maximizing Equipment Operation Time

Smart Care

Hanwha Power operates four preventive maintenance programs based on accumulated operating hours to prevent unexpected equipment failures.

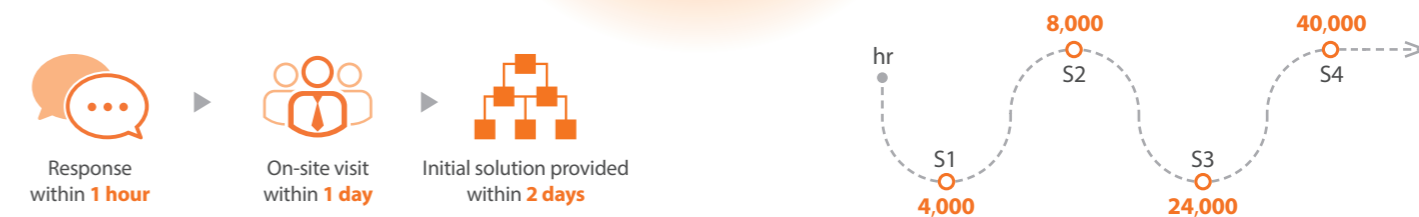

AM Solutions

Operational Services

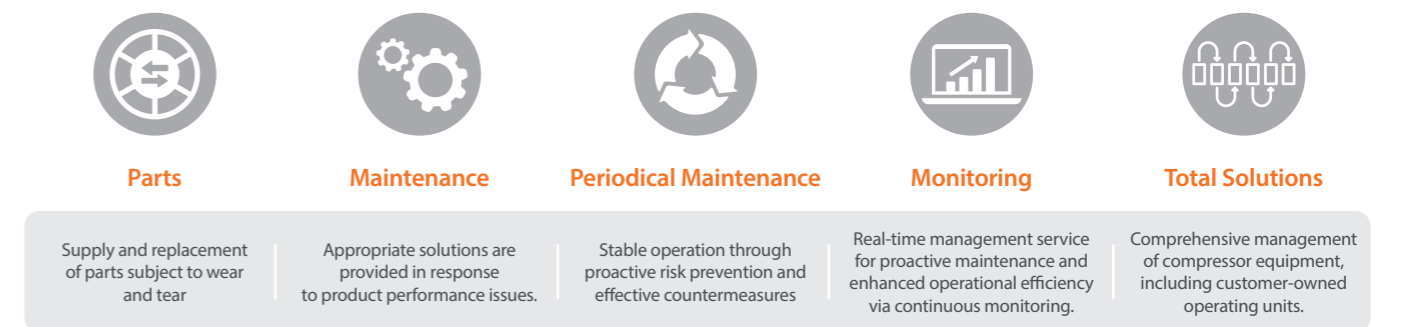

Operational Objectives

- ✓ **Establishment of Management System**
Rapid and accurate system implementation through designated management personnel
- ✓ **Risk Management**
Comprehensive oversight via regular inspections and diagnostics
- ✓ **Cost Reduction**
Enhancing equipment efficiency while extending service life